



Innovation, Quality and Expertise for Gas Detection.

## SureCell - CO (H)

### Operating Performance

Operating Principle	3-electrode electrochemical
Gas Detected	Carbon Monoxide
Measurement Range	0-500 ppm
Maximum Overload <sup>2</sup>	1000 ppm
Expected Operating Life	2 years in air
Output Signal	0.11 ±0.02µA per ppm
Temperature Range	Continuous: -20°C to +40°C Intermittent: -40°C to +55°C
Pressure Range	1 atm ±10%
Humidity Range (non-condensing)	Continuous: 15 - 90% Intermittent: 0 - 99%
Response Time (T <sup>5</sup> <sub>90</sub> )	<30 seconds
Baseline Offset (clean air)	<±3ppm equivalent
Zero Shift (-40 to +55°C)	<±2ppm equivalent
Long Term Output Drift	<5% per annum
Repeatability	<±5%
Linearity	Linear ±<5%
Recommended Load Resistor	5Ω
Bias Voltage	Not required

### Intrinsic Safety Data

Maximum at 1000ppm	0.2mA
Maximum o/c Voltage	1.3V
Maximum s/c Current	<1.0A

### Physical Specification

Weight	5g (approx)
Housing Material	Noryl 110
Storage Life	6 months in sealed container
Storage Conditions	+10°C to +30°C
Orientation	Any
Warranty Period	18 months from date of despatch

### Ordering Details

Part Number	2112B2004
-------------	-----------

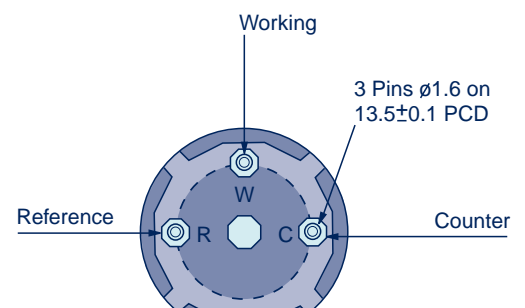
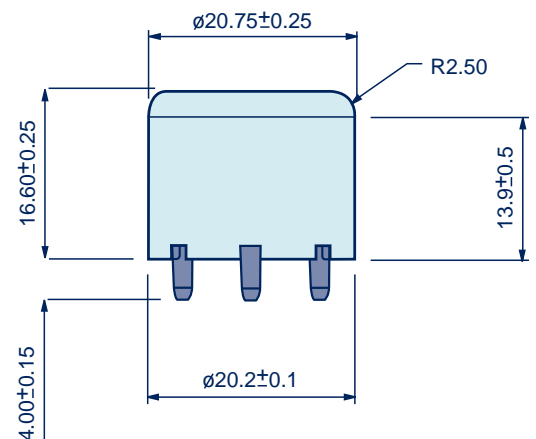
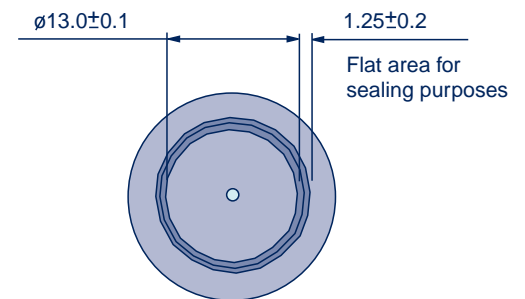



## Additional Information

Innovation, Quality and Expertise for Gas Detection.

Linearity of CO (H) SureCells (0 to 1000 ppm)

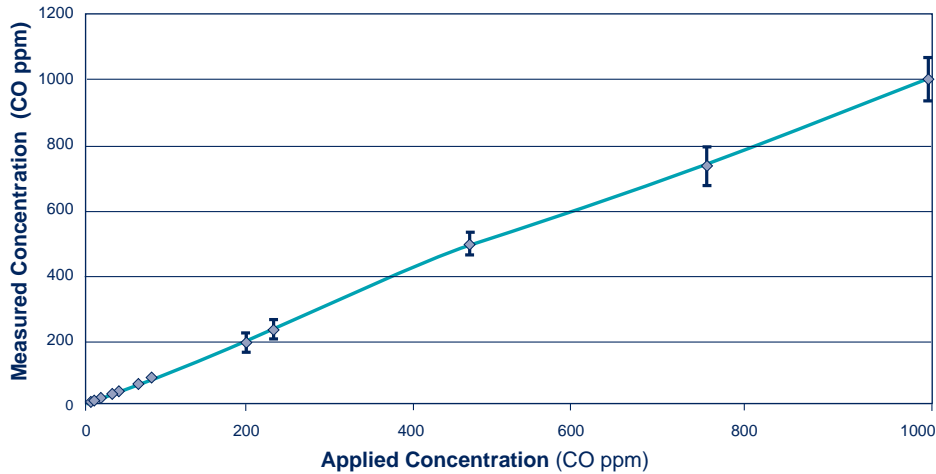

Temperature Coefficients of CO SureCells

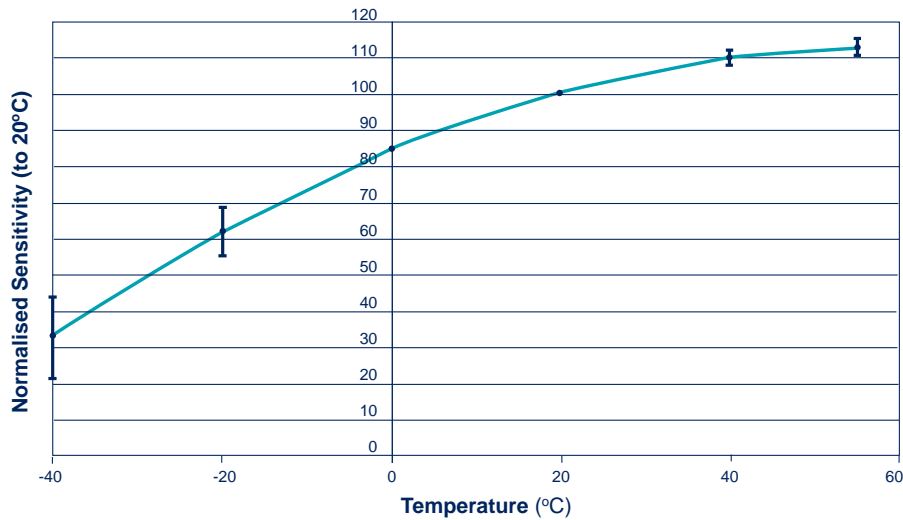

Cross Sensitivity Table

Gas	Concentration Used (ppm)	Reading (ppm CO)	Gas	Concentration Used (ppm)	Reading (ppm CO)
Carbon Monoxide	50	50	Ethylene	100	85
Hydrogen Sulphide	10	38	Carbon Dioxide	5000	0
Sulfur Dioxide	2	1	Ammonia	50	0
Nitrogen Dioxide	3	-1	Methane	5000	0
Chlorine	2	<+2	Ethanol	40	12
Hydrogen	100	10			

In the interest of product improvement, Sixth Sense reserves the right to alter design features and specifications without notice. Unless otherwise stated, all product specifications are quoted at standard temperature and pressure.

**\*Note:** The figures in this table are typical values and should not be used as a basis for cross calibration. Cross sensitivities may not be linear and should not be scaled. All data based on a 5 minute gassing. For some cross interferences break through will occur if gas is applied for a longer time period.