

SF340 CARBON MONOXIDE ALARM

The SF340 series is a range of reliable, hard wired Carbon Monoxide alarms with battery backup. They are designed for use in all domestic and light commercial environments.

Why choose the SF340 Carbon Monoxide (CO) alarm:

- Unique 5 year module replacement system
- Up to 5 years battery back up
- Low maintenance
- Secure installation
- 230Vac and 12/24Vdc options
- Easy integration within existing systems
- Interconnect and relay output options
- No re-wiring or main unit replacement costs



Features & Benefits

Every unit in the SF340 series utilises advanced ECO-Sure electrochemical cell sensing technology and comes complete with a 10 year guarantee on each sensor module.

The SF340 series offers up to 5 years battery back-up allowing for continuous protection – even in the event of power loss. This also allows the unit to be operational whilst waiting for permanent installation.

The SF340 is specially designed for permanent, secure installation and is ideal for use by local authorities, housing associations and any organisation responsible for the safety of tenants and the maintenance of their homes.



EURO-GAS MANAGEMENT SERVICES LTD, REVELSTOKE HOUSE,
STOKE ROAD, NOSS MAYO, PLYMOUTH, DEVON PL8 1EY, UK

☎: +44 (0)1752 872222 Fax: +44 (0)1752 872223
euro-gas@btconnect.com www.euro-gasman.com



EURO-GAS
MANAGEMENT SERVICES LTD

SF340 CARBON MONOXIDE ALARM

The series incorporates a unique module replacement system. There are no re-wiring or main unit replacement costs, just a simple, clip-in module to change once every 5 years. This results in low ownership costs and minimal maintenance. Locking screws ensure only authorised persons can gain access to each unit.

Units are available with relay output and interconnect options. This enable connection to control panels, shut-off valves, remote alarms, etc., as well as allowing numbers of alarms to be linked together in series.

An internal diagnostic facility means the SF340 carries out continuous self-monitoring. If any fault occurs in the sensor, battery or circuits, the unit will automatically give a warning signal within 60 seconds.

Specification

Detection Principle:	Electrochemical cell
Operating Voltage:	230Vac or 12/24Vdc
Backup Battery:	9Vdc pp3
Power Consumption:	<2.5W
Main Unit Life:	No replacement required (10 year guarantee)
Module Life:	5 years (guaranteed)
Module Replacement Warning:	Double buzzer chirp every minute
Alarm Indication:	Buzzer and flashing red light
Buzzer Output:	85 decibels (dB) at 3m
Operating Temperature Range:	-5 to +40°C
Alarm Levels (BS7860: 1996):	150ppm between 10-30 minutes 350ppm within 6 minutes
Weight:	575g approx.
Dimensions:	170mm x 110mm x 65mm
Test Facility:	Yes
Relay Output Fitted:	SF340F and SF340J
Models Available:	SF340E – 230Vac SF340F – 230Vac + relay + interconnect SF340J – 12/24Vdc + relay + interconnect

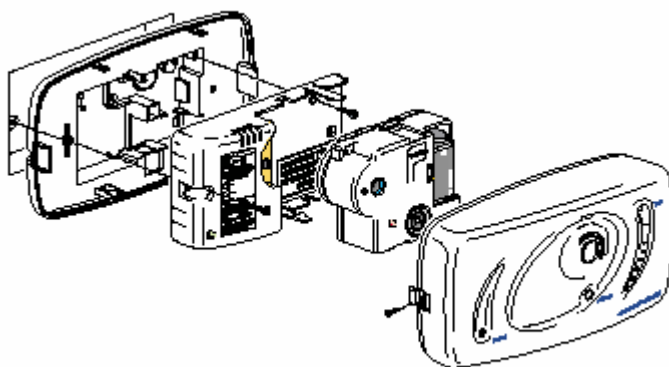

Please Note: Whilst every effort has been made to ensure accuracy in this publication, no responsibility can be accepted for errors or omissions. Data may change, as well as legislation, and you are strongly advised to obtain copies of the most recently issued regulations, standards and guidelines.



EURO-GAS MANAGEMENT SERVICES LTD, REVELSTOKE HOUSE,
STOKE ROAD, NOSS MAYO, PLYMOUTH, DEVON PL8 1EY, UK

☎: +44 (0)1752 872222 Fax: +44 (0)1752 872223
euro-gas@btconnect.com www.euro-gasman.com

EURO-GAS
MANAGEMENT SERVICES LTD