

HYDROGEN H₂ SS SENSOR + 1.8V TRANSMITTER

SPECIFICATION

Operating Principle: Amperometric, 3-electrode cell
4-pin and socket connector

Gas Detected: Hydrogen H₂

Measurement Range: 0 – 20,000 ppm

Lower Detectable Limit (LDL): 100 ppm

Maximum Range: 40,000 ppm

LEL: 40,000 ppm

Sensor Expected Operating Life: 5 years

Temperature Range: -20°C to +60°C

Humidity Range (non-condensing): 15 - 90% RH

Response Time (T50): <10 seconds

Response Time (T90): <30 seconds

Long Term Sensitivity Drift: <20% per year

Deviation From Linearity at Standard Range: < 20% FS

Zero Voltage at Normal Conditions: 200mV (shifted for Offset)

Sensitivity: 0.04 to 0.08 mV/ppm

Sensor Warm-Up Time (typical): 20 seconds

Temperature Dependence: < 1% / °C incl. NTC
temperature compensation

Sensor dimensions: Ø 20.3mm; Height 26.5mm

Warranty Period: 6 months from date of despatch

Part Number: 2112B012410

Additional Options: Available as 5V transmitter and as sensor only options. Please ask Euro-Gas for details.

1.8V transmitter – ideal for battery operated applications.
Part Number: 2112B012410



HYDROGEN H₂ SS SENSOR + 1.8V TRANSMITTER

DIMENSIONS

(all dimensions in mm ± 0,15 mm tolerance)

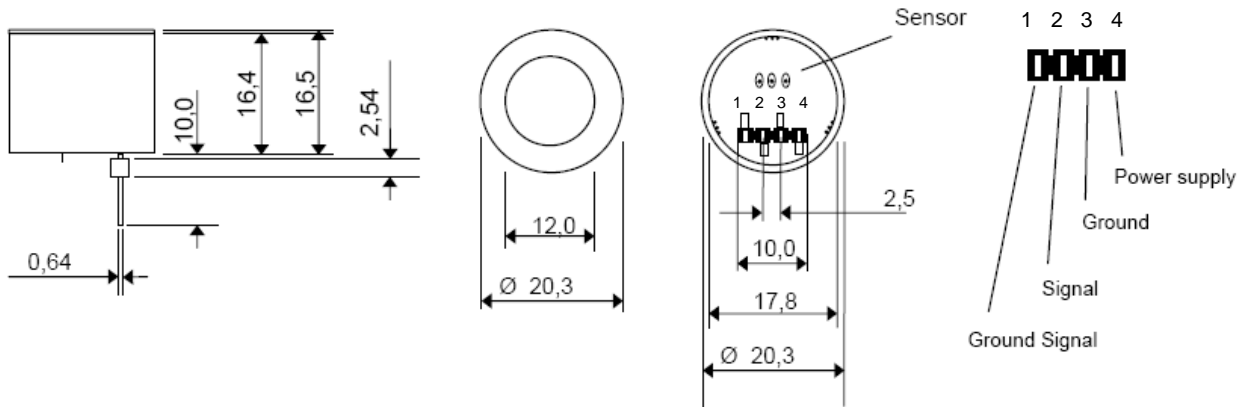

Supply Voltage:

2.8V to 3.3V with pin and socket connector

Analogue output range:

0.2V to 1.8 V

CROSS SENSITIVITY DATA

GAS	CONCENTRATION	READING IN PPM
Ammonia NH ₃	25 ppm	0
Carbon Dioxide CO ₂	5000 ppm	0
Carbon Monoxide CO	50 ppm	37
Chlorine Cl ₂	1.0 ppm	0
Hydrocarbons unsaturated	1%	0
Hydrogen H ₂	1000 ppm	1000
Hydrogen Sulphide H ₂ S	10 ppm	0
Isopropanol C ₃ H ₇ OH	1000 ppm	0
Nitric Oxide NO	20 ppm	To be advised
Nitrogen Dioxide NO ₂	10 ppm	To be advised
Ozone O ₃	0.5 ppm	0
Sulphur Dioxide SO ₂	20 ppm	To be advised

Note: Test conditions at 20°C / 1013 hPa, flow rate > 500 qcm/min.
Cross-sensitivity gases are not target gases. Relationship can change over time.



EURO-GAS MANAGEMENT SERVICES LTD, REVELSTOKE HOUSE,
STOKE ROAD, NOSS MAYO, PLYMOUTH, DEVON PL8 1EY, UK

☎: +44 (0)1752 872222 Fax: +44 (0)1752 872223

euro-gas@btconnect.com www.euro-gasman.com

EURO-GAS
MANAGEMENT SERVICES LTD

HYDROGEN H₂ SS SENSOR + 1.8V TRANSMITTER

TRANSMITTER OPTIONS

5V Model

Also available as a 5V model, with trim potentiometer and LED power signal.

Please ask Euro-Gas for details.

Supply voltage: 6V – 24V
Output range: 1V - 5V
Part no: 2112B013410

SENSOR OPTIONS

The H₂ SS sensor is also available as sensor only options and as housed systems:

Raw sensor:	part no. 2112B010210
Micro sensor:	part no. 2112B012710
4 series sensor:	part no. 2112B010410
USB gas sensor stick:	part no. 2112B051001

H₂ Gas Measuring System in PVC housing:
part no. 2112B0090

H₂ Gas Measuring System in aluminium housing:
part no. 2112B24420



The data contained in this document is believed to be accurate and reliable. The data given is for guidance only. Euro-Gas Management Services Ltd accepts no liability for any consequential losses, injury or damage resulting from the use of this datasheet or the information contained in it. Customers should test the sensors under their own conditions to ensure that the sensors are suitable for their own requirements and in accordance with the plans and circumstances of the specific project and any standards/regulations pertaining to the country in which the sensors will be utilised. This datasheet is not intended to form the basis of a contract and in the interest of product improvement, Euro-Gas reserves the right to alter design features and specifications without notice.

02/12



EURO-GAS MANAGEMENT SERVICES LTD, REVELSTOKE HOUSE,
STOKE ROAD, NOSS MAYO, PLYMOUTH, DEVON PL8 1EY, UK

☎: +44 (0)1752 872222 Fax: +44 (0)1752 872223
euro-gas@btconnect.com www.euro-gasman.com

EURO-GAS
MANAGEMENT SERVICES LTD