

- Read before use!
- Observe all safety instructions!
- Keep for future reference!



# Operating Instructions

## Gas Indicator System

### GMS-TRL4 + GMS-RZ

EURO-GAS MANAGEMENT SERVICES LTD, REVELSTOKE HOUSE,  
STOKE ROAD, NOSS MAYO, PLYMOUTH, DEVON PL8 1EY, UK

☎: +44 (0)1752 872222 Fax: +44 (0)1752 872223  
euro-gas@btconnect.com www.euro-gasman.com



**EURO-GAS**  
MANAGEMENT SERVICES LTD

**Contents**

- 1. For your safety .....2
  - 1.1 Safety information and tips .....3
  - 1.2 Intended use .....3
  - 1.3 Other dangers.....5
  - 1.4 Qualification of personnel .....6
- 2. Product description.....6
  - 2.1 Design of the gas indicator system .....6
  - 2.2 GMS-TRL4.....7
  - 2.3 GMS-RZ.....7
  - 2.4 Technical data .....8
  - 2.5 Certification.....10
- 3. Transport and installation .....10
  - 3.1 Transport .....10
  - 3.2 Storage .....10
  - 3.3 Installation.....10
  - 3.4 Electrical connection.....11
- 4. Operation .....13
  - 4.1 Commissioning .....13
  - 4.2 Calibration.....13
  - 4.3 Function test .....14
  - 4.4 Output signals and fault messages.....14
- 5. Maintenance and servicing.....14
  - 5.1 Sensor replacement.....16
- 6. Decommissioning.....16
- 7. Packaging and transport .....16
- 8. Disposal .....16
- 9. Appendix .....17
  - 9.1 Spare parts and accessories .....17
  - 9.2 Harmful substances .....17
  - 9.3 Copyright .....17
  - 9.4 Warranty .....17

## 1. For your safety

### Observe the instructions for use

Any person handling or operating the gas indicator system must first be fully familiar with and observe these instructions for use. The gas indicator system is only to be used for the described purpose (see section 1.2).

### Servicing

The gas indicator system must be inspected and serviced regularly by qualified specialists. Repairs to the gas indicator system must only be carried out by qualified specialists. (See sections 1.4 and 5.)

### Do not operate in areas subject to explosion hazards

The gas indicator system is not approved for operation in areas subject to explosion hazards. Do not operate it in any areas where combustible or explosive gas mixtures are likely to occur.


### WARNING!

These operating instructions do not contain all the information necessary for the safe operation of the device. Please acquaint yourself with the regulations and operator's obligations that apply in your area. In addition to these operating instructions, for example, you should observe and instruct others concerning the universally valid legal and other binding regulations for the prevention of accidents and protection against accidents.

#### 1.1 Safety information and tips

A series of warnings is used in these instructions concerning some of the risks and dangers that may occur when using the gas indicator system. These warnings contain "signal words" designed to draw attention to the degree of danger that is to be expected.

These signal words and the associated hazards are as follows:

	<p><b><u>DANGER!</u></b> Indicates an <b>imminently</b> hazardous situation which, if not avoided, <b>will</b> result in <b>death or serious injury</b>. This signal word is to be limited to the most extreme situations.</p>
---	--

**WARNING!**

Indicates a **potentially** hazardous situation which, if not avoided, **could** result in **death or serious injury**.

**CAUTION!**

Indicates a **potentially** hazardous situation which, if not avoided, **may** result in **minor or moderate injury**. It may also be used to alert against unsafe practices.

**IMPORTANT!**

Indicates information concerning use and other useful information.

## 1.2 Intended use

The GMS-TRL4 + GMS-RZ gas indicator system has been designed especially for monitoring the concentration of carbon monoxide (CO concentration) in garages.

It may therefore be used exclusively for:

- Monitoring the concentration of carbon monoxide in the air in traffic structures in which exhaust fumes arise when motor vehicle engines are left running, i.e. garages, underground parking garages, multi-storey car parks, go-cart tracks.

It is essential that the gas indicator system is installed only as described in section 3.3 and that the ambient conditions specified in sections 2.4 and 3.3 (e.g. temperature limits) are adhered to!

**DANGER!****Danger to life due to carbon monoxide poisoning!**

The carbon monoxide monitored by the gas indicator system is a component of vehicle exhaust fumes and is very poisonous. At a concentration of as little as 400ppm, it causes unconsciousness and respiratory paralysis, resulting in death. Users and operators of the facility must make sure that, where there is a raised concentration of carbon monoxide, suitable measures are taken to protect people in accordance with legal regulations (In Germany, the regulations of the Association of German Engineers VDI 2053 "Air Treatment Systems for Car Parks" have to be observed.) Examples of this include an increased supply of fresh air, a ban on leaving engines running, evacuation of the facility.



**DANGER!**

**Danger to life due to carbon monoxide poisoning!**

The gas indicator system's carbon monoxide sensor has a limited service life. Regular function checks and maintenance (see section 5) are therefore imperative. **The gas indicator system does not indicate when the sensor has expired!**



**WARNING!**

**Danger of fire and explosion due to sparks!**

The GMS-TRL4 + GMS-RZ gas indicator system may not be operated in areas where ignitable or explosive gas mixtures can arise.



**WARNING!**

Gas indicator systems are safety devices and may only be repaired by the manufacturer.

Do not modify the gas indicator system and do not reconstruct it. It may otherwise no longer monitor the concentration of carbon monoxide reliably.



**IMPORTANT!**

The alarm signals from the GMS-RZ gas indicator system must be evaluated and further processed by the user's downstream device.



**IMPORTANT!**

It is essential to observe the information given in these operating instructions with regard to operation, maintenance and servicing.





**IMPORTANT!**

Faults must be rectified immediately as they impair safety.

### 1.3 Other dangers

Despite its careful design, there remain some further dangers associated with handling the gas indicator system. The following are known to us:

	<p><b><u>DANGER!</u></b> Mains voltage (230 V, 50 Hz). <b>Danger to life due to electric shock or burns.</b> Do not bring into contact with water. Before opening the gas indicator system, disconnect the mains voltage safely (safe electrical isolation). Electrical work should only be carried out by a qualified electrician. Only install in a voltage-free state.</p>
	<p><b><u>DANGER!</u></b> <b>Danger to life due to carbon monoxide poisoning!</b> Certain external circumstances can mean that the gas indicator system is <b>unable to signal</b> a possible increased concentration of carbon monoxide, e.g. in the event of a power failure. In this case, users and operators of the facility must make sure that suitable measures are taken to protect people in accordance with the legal regulations.</p>

### 1.4 Qualification of personnel

Only qualified mechatronic engineers or persons with comparable training may mount, install or commission the gas indicator system or carry out maintenance and servicing work.

Only qualified electricians may carry out work on the electrical system (in Germany according to VDE).

The operator must instruct all users of the system on the basis of these operating instructions.

The minimum age is 16 years. An experienced person must supervise juveniles and apprentices when working on the gas indicator system.

Any work that is not described in these operating instructions must be executed by the manufacturer.

## **2. Product description**

### **2.1 Design of the gas indicator system**

This gas indicator system has four alarm thresholds and is especially designed for monitoring the concentration of carbon monoxide in garages. It consists of a maximum of 20 carbon-monoxide-specific GMS-TRL4 gas indicator systems and two GMS-RZ relay centres. The GMS-TRL gas indicator system emits four alarms, whereby the alarm outputs are designed as Transistor Resistor Logic (TRL). As a result it is possible to connect up two alarm outputs each in an OR operation to a GMS-RZ relay centre (parallel connection). The relay centre initiates a maximum two-step reaction to an excessive concentration of carbon monoxide. Groupings are easily possible. The alarm signals from the GMS-RZ gas indicator system must be evaluated and further processed by the user's downstream device.

### **2.2 GMS-TRL4**

The specific electrochemical sensor that measures the concentration of carbon monoxide in the air is located in the aluminium sensor head. The measured signals are evaluated and processed in the transmitter integrated in the plastic housing. If the measured value exceeds the programmed alarm threshold A1, A2, A3 or A4, an alarm signal is emitted via the relevant alarm output and the TRL output there switches to 0 (*low active*). Ex works, the alarm threshold for A1 is 30 ppm CO, A2 is 40 ppm CO, A3 is 50 ppm CO and A4 is 60 ppm CO. Customer-specific modifications to the alarm thresholds are possible.

## 2.3 GMS-RZ

It is possible to connect 2 alarm outputs of up to 20 GMS-TRL4 gas indicator systems to the GMS-RZ relay centre. The output signals from the GMS-RZ can be picked up via potential-free relay contacts (load 250V AC 1A). Three LEDs indicate the function status.



Fig. 1: GMS-TRL4 + GMS-RZ gas indicator system.

## 2.4 Technical data

GMS-TRL4		
Power supply		Screw terminals
	Terminal voltage	18 to 28 V DC
	Current	$I_{typ} = 20 \text{ mA}$ at approx. 10 ppm CO $I_{max} = 50 \text{ mA}$
Connections	Terminal 1 (in)	$U_{typ} = 24 \text{ V DC} \pm 5\%$
	Terminal 2 (in)	0 V
	Terminal 3 (out)	Alarm 1, <i>low active</i>
	Terminal 4 (out)	Alarm 2, <i>low active</i>
	Terminal 5 (out)	Alarm 3, <i>low active</i>
	Terminal 6 (out)	Alarm 4, <i>low active</i>
Ambient temperature	-10° C to +40° C	
Air pressure	900 hPa to 1100 hPa	
Permissible humidity	15-95% rel. humidity	
Output	TRL	Transistor Resistor Logic
	Alarm 1	30 ppm CO
	Alarm 2	40 ppm CO

	Alarm 3	50 ppm CO
	Alarm 4	60 ppm CO
Protection class of housing	IP 65	Grey plastic housing
Protection class of sensor head	IP 40	Aluminium
Weight of housing	Approx. 150 g	
Size of housing	Approx. W95 x H60 x D44 mm	
Connecting cable	6x1.5 <sup>2</sup> Cu	Shielded cable as required; min. 18 V at supply terminal
<b>GMS-TRL4 sensor</b>		
Gas access	By diffusion	
Gas measured	Carbon monoxide (CO)	
Measuring range	0 to 300 ppm	
Accuracy	Deviation < 2% of FS	FS= Full Scale
Reproducibility	Deviation < 0.5% of FS	
Reaction time T <sub>90</sub>	< 130 s	
Response sensitivity	< 3 ppm	
Error limit of measured value	< 2% of FS	
Linearity	< 2% of FS	
Zero drift	< 4 ppm	
Pressure sensitivity	< 1%	Within the range of normal air pressure fluctuations.
Cross sensitivity	< 0.5% of FS at	7 ppm SO <sub>2</sub> ; 1 ppm NO 0.5 ppm NO <sub>2</sub> ; 1000 ppm CO <sub>2</sub> 100 ppm toluene, xylene
<b>GMS-TRL4 controls</b>		
Potentiometer P	Setting of measured value	
Test pins TP1 and TP2	Reading of measured value	
<b>GMS-RZ</b>		
Power supply		Screw terminals
	Voltage	24 V DC ± 5%
Nominal power	Without measuring systems	Approx. 3 W
Ambient temperature	-10° C to +40° C	
Air pressure	900 hPa to 1100 hPa	
Permissible humidity	15-95% rel. humidity	
Housing	Plastic	Grey, rail
Protection class of housing	IP 20	
Weight of housing	Approx. 100 g	
Size of housing	Approx. W35 x H91 x D72 mm	
<b>GMS-RZ connections</b>		
External power supply	Terminal K1 (in)	24 V DC ± 5%

	Terminal K2 (in)	0 V
GMS-TRL4	Terminal K3 (out)	24 V DC $\pm$ 5%
	Terminal K4 (in)	Alarm A1 or A3
	Terminal K5 (in)	Alarm A2 or A4
	Terminal K6 (out)	0 V
Relay alarm AI1	Terminal 7	NC contact (normally closed)
	Terminal 8	Two-way switch
	Terminal 9	NO contact (normally open)
	Idle state	Alarm AI1
Relay alarm AI2	Terminal 10	NC contact
	Terminal 11	Two-way switch
	Terminal 12	NO contact
	Idle state	Alarm AI2
GMS-RZ optical display		
Green LED	Operation	
Red LEDs AI1, AI2	Alarm1 and Alarm2	

## 2.5 Certification

The gas indicator system complies with EMC Directives EN 61000-6-2 and EN 61000-6-3 and thus Directives 89/336/EEC and 92/31/EEC.

## 3. Transport and installation

### 3.1 Transport

The gas indicator system is supplied together with these operating instructions. Please check the packaging for any damage when the product is delivered and report any damage immediately to the forwarding agency and dealer. The gas indicator system should not be thrown or dropped as it could be damaged or scratched. Protect against wet conditions, humidity, dirt and dust.

### 3.2 Storage


The gas indicator system may be stored in its packaging in dry rooms at temperatures between +10°C and +50°C. Protect it against wet conditions, humidity, dirt and dust.

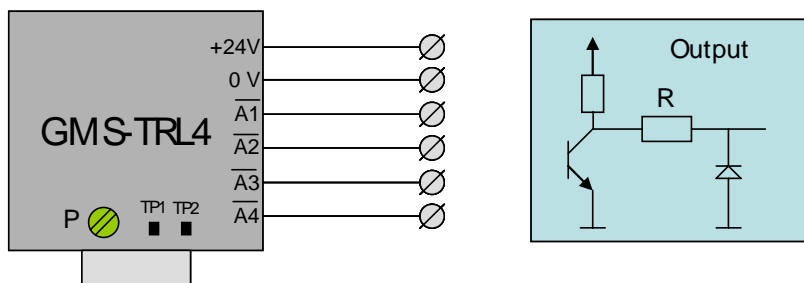
### 3.3 Installation

Each TRL4 and GMS-RZ gas indicator system must be mounted in the room on a level, firm and dry wall or rail. Please observe the valid legal regulations. In Germany, they are described in VDI 2053, according to which, for example, the GMS-TRL4 must be fitted at a height of at least 1.50 m and the section monitored by each GMS-TRL4 must be no greater than 400 m<sup>2</sup>.

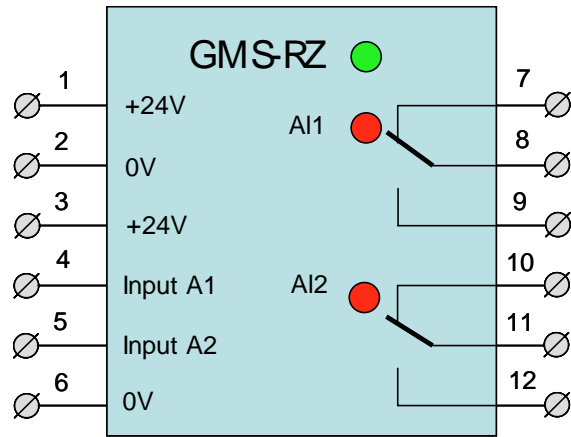
<b>i</b>	<p><b><u>IMPORTANT!</u></b></p> <p>When installing, it is essential to remain within the following permissible ambient conditions: Ambient temperature of housing between -10 and <b>+40° C</b> (Do not expose to direct sunlight!). The housing must be freely accessible and visible at all times. If installed outdoors, protect the housing from adverse weather conditions. The gas indicator system must not be in contact with water. This includes <b>no splash water</b> and <b>no condensation!</b> The gas indicator system must not be installed in damp locations or areas subject to explosion hazards.</p>
----------	---

### 3.4 Electrical connection

	<p><b><u>DANGER!</u></b></p> <p>Mains voltage (230 V, 50 Hz). <b>Danger to life due to electric shock or burns.</b> Do not bring into contact with water. Before opening the gas indicator system, disconnect the mains voltage safely (safe electrical isolation). Electrical work should only be carried out by a qualified electrician. Only install in a voltage-free state.</p>
---	--

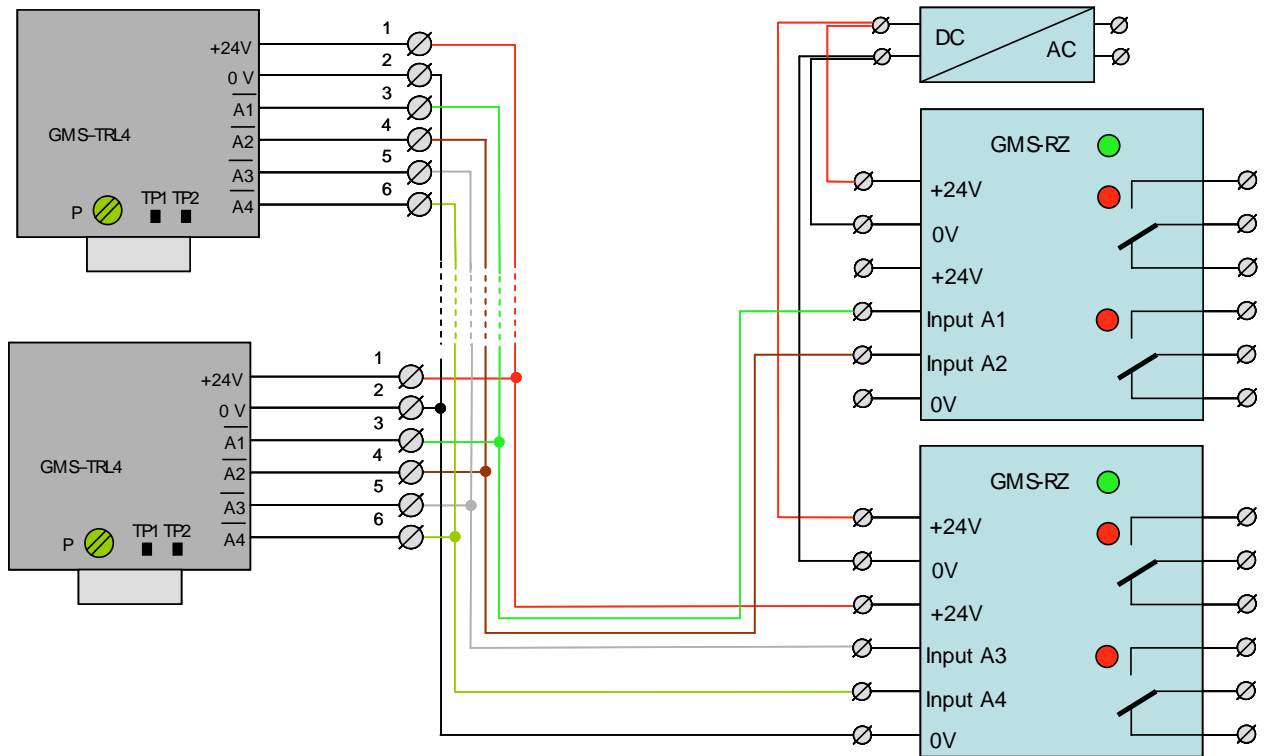


**Fig. 2:** GMS-TRL4 terminal assignment. The outputs are short-circuit-proof.



**Fig. 3:** GSM-RZ terminal assignment. The output signals from the GSM-RZ can be picked up via potential-free relay contacts (load 250V AC 1A). Illustrated currentless.

The GSM-TRL4 and GSM-RZ must be connected by means of a permanent, six-core cable (see Fig. 4). Do not lay this line next to a high-tension power cable as there is a danger of radiated interference. The cable must be capable of withstanding the anticipated mechanical, chemical and thermal stresses.



**Fig. 4:** GSM-TRL4 + GSM-RZ gas indicator system. Max. 20 GSM-TRLs may be connected to 2 GSM-RZs in total. Illustrated currentless.

The output signals from the GMS-RZ can be picked up via potential-free relay contacts. Load 250 V AC 1A.



**CAUTION!**

In accordance with existing safety regulations the gas indicator system must only be connected to suitable power supply units that comply with the valid technical regulations. It must be ensured that fuse protection is provided that is suitable for the power supply units used (SAFE ELECTRICAL ISOLATION)!

## 4. Operation

### 4.1 Commissioning

Before commissioning use the following list to check whether all requirements for trouble-free operation are met:

- Is each component of the gas indicator system installed (all necessary GMS-TRL4 and GMS-RZ units)?
- Is the housing freely accessible and visible?
- Have the ambient conditions been taken into account?
- Has the gas indicator system been connected?
- Is the power supply switched on?
- Are you sure that the connection cable is not laid next to high-tension power cable?
- Please bear in mind that this is a sensitive measuring instrument!

The next step is to carry out the calibration and a function test and generate a protocol relating to the commissioning (see section 9.4, Warranty).

### 4.2 Calibration

Calibration is carried out by means of a potentiometer inside the GMS-TRL4 housing. This requires test gas and a voltmeter.

- Ensure that the power supply is safely below 28 V.
- Only then should you remove the cover from the GWZ-TRL4 and place the voltmeter on test pins TP1 and TP2. (Voltmeter on measuring range 0-2 V.)

- Deliver the test gas with 300 ppm CO (test gas flow < 0.4 l/min) and turn the potentiometer continuously until the voltmeter shows 2.0 V.
- Remove the test gas and voltmeter.
- Screw the housing shut.
- Carry out the function test.

#### 4.3 Function test

- Deliver test gas with 300 ppm CO to the sensor head and check the reaction of the GMS-RZ relay centre: the test gas must trigger alarm AI2 on the GMS-RZ to which alarm output A4 is connected (main alarm).
- Remove test gas. GMS-RZ returns to the original state after falling below the alarm threshold.



#### **IMPORTANT!**

Calibration and the function test must be carried out in full for **each** connected GMS-TRL4.

#### 4.4 Output signals and error messages

- GMS-TRL4 output signals:  
Alarm A1, A2, A3 and A4, Transistor Resistor Logic (TRL), *low active*.
- GMS-RZ output signals:  
Alarm AI1 and AI2, relay logic.
- Short circuit and cable breakage:  
GMS-RZ signals Alarm AI1 and/or AI2 and does not return to its original state despite falling below the alarm threshold.

### 5. Maintenance and servicing



#### **WARNING!**

Gas indicator systems are safety devices and must only be repaired by the manufacturer.

Do not modify the gas indicator system and do not reconstruct it. It may otherwise no longer monitor the concentration of carbon monoxide reliably.



**DANGER!**

Mains voltage (230 V, 50 Hz).

**Danger to life due to electric shock or burns.**

Do not bring into contact with water.

Before opening the gas indicator system, disconnect the mains voltage safely (safe electrical isolation).

Electrical work should only be carried out by a qualified electrician.

Only install in a voltage-free state.

The gas indicator system and connection cable must be checked at least every six months by qualified personnel (see section 1.4) and a servicing report must be prepared. The check must include calibration and a function test on the devices as described in sections 4.2 and 4.3. Always ensure that the interval between services meets safety requirements. This may mean that checks need to be carried out more frequently!



**DANGER!**

**Danger to life due to carbon monoxide poisoning!**

The gas indicator system's carbon monoxide sensor has a limited service life. **The gas indicator system does not indicate when the sensor has expired!**

After any interruption in operation or any malfunction, carry out calibration and a function test for each connected GMS-TRL4 (see sections 4.2 and 4.3). If it is not possible to calibrate the GMS-TRL4 or trigger the main alarm, check the system for cable breakage or a short circuit. If the wiring is in order, please replace the sensor for the GMS-TRL4 concerned (see section 5.1). If after this the GMS-TRL4 still does not work, please replace the device. If this is also not successful, please inform the manufacturer or dealer immediately.



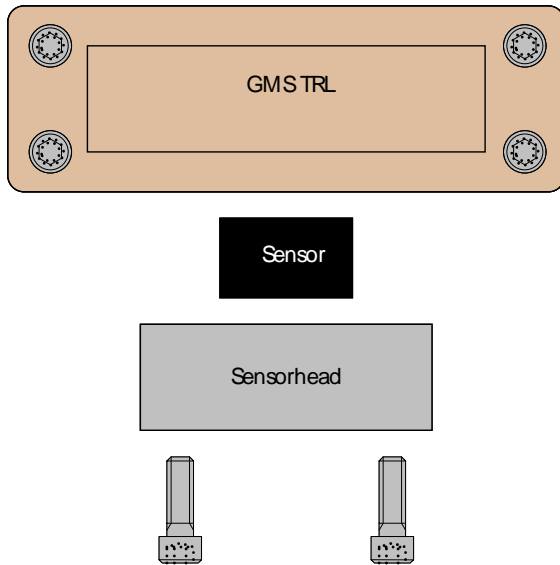
**DANGER!**

**Danger to life due to carbon monoxide poisoning!**

Please make sure that no impermissibly high CO values can occur while the system is being serviced or maintained.

Make appropriate checks to ensure that the gas indicator system and its surrounding area is always clean, accessible and visible.

## 5.1 Sensor replacement



- Unscrew the screws from the sensor head.
- Remove the sensor head.
- Pull the sensor off the plug-in contact.
- Attach the new sensor to the plug-in contact.
- Return the sensor head.
- Tighten the screws.
- Calibrate the device as described in section 4.2

## 6. Decommissioning

Switch off the power supply. For storage it is essential to refer to section 3.2.

## 7. Packaging and transport

This device is a measuring instrument with sensitive electronic components. When returning it, please use the appropriate class of packaging according to the applicable regulations.

## 8. Disposal

Obsolete devices should be rendered unusable immediately and disposed of according to the relevant regulations. Please contact your local authority for information about disposal.

## **9. Appendix**

### **9.1 Spare parts and accessories**

Sensors

### **9.2 Harmful substances**

There are currently no known, nor any anticipated, sensor-specific catalyst poisons that could damage the electrochemical sensor beyond repair.

### **9.3 Warranty**

Euro-Gas grants a warranty for this device for a period of 6 months from commissioning, documented by a commissioning report. Within this warranty period we will at our discretion, repair or replace the device free of charge if found to be defective as to workmanship or material.

The warranty excludes: damages attributable to improper use, normal wear (e.g. electrochemical sensor), and defects that have only a negligible influence on the device's value or suitability for use.

Liability for the functioning of the gas indicator system shall pass at all events to the owner or operator if the gas indicator system is improperly maintained or repaired or if it is used other than for its intended purpose. Euro-Gas accepts no liability for damage caused by failure to observe the above information.

The warranty expires in the event that work is carried out by agents we have not authorised or if parts are used other than original spare parts.

Claims under the warranty may be made in all countries where this device is sold by authorised dealers.

In the event of any claim under the warranty, please return the device to us. The buyer shall bear the costs of transportation and the risk while the device is in transit. The execution of work under the warranty does not affect the warranty period in any way.

The manufacturer accepts no liability for printing errors or any damage resulting therefrom. The above information does not extend the conditions of warranty and liability contained in the Terms and Conditions of Sale and Delivery of Euro-Gas.

Subject to change without notice. (03/10)

The data given in this datasheet is provisional and may be subject to change. The data contained in this document is believed to be accurate and reliable. The data given is for guidance only. Euro-Gas Management Services Ltd accepts no liability for any consequential losses, injury or damage resulting from the use of this datasheet or the information contained in it. Customers should test the sensors under their own conditions to ensure that the sensors are suitable for their own requirements and in accordance with the plans and circumstances of the specific project and any standards/regulations pertaining to the country in which the sensors will be utilised. This datasheet is not intended to form the basis of a contract and in the interest of product improvement, Euro-Gas reserves the right to alter design features and specifications without notice.