

CE

Technical Data Sheet
Gas Indicator System
GMS-TRL4 + GMS-RZ

EURO-GAS MANAGEMENT SERVICES LTD, REVELSTOKE HOUSE,
STOKE ROAD, NOSS MAYO, PLYMOUTH, DEVON PL8 1EY, UK

☎: +44 (0)1752 872222 Fax: +44 (0)1752 872223
euro-gas@btconnect.com www.euro-gasman.com



EURO-GAS
MANAGEMENT SERVICES LTD

1. Features

This gas indicator system has four alarm thresholds and is especially designed for monitoring the concentration of carbon monoxide in garages. It consists of a maximum of 20 carbon monoxide (CO)-specific GMS-TRL4 gas indicator systems and two GMS-RZ relay centres. The GMS-TRL gas indicator system emits four alarms, whereby the alarm outputs are designed as Transistor Resistor Logic (TRL). As a result it is possible to connect up two alarm outputs each in an OR operation to one GMS-RZ relay centre (parallel connection). The relay centre initiates a maximum two-step reaction to an excessive concentration of carbon monoxide. Groupings are easily possible. The alarm signals from the GMS-RZ gas indicator system must be evaluated and further processed by the user's downstream device.

2 Design of the gas indicator system

2.1 GMS-TRL4

The specific electrochemical sensor that measures the concentration of carbon monoxide in the air mixture is located in the aluminium sensor head. The measured signals are evaluated and processed in the transmitter integrated in the plastic housing. If the measured value exceeds the programmed alarm threshold A1, A2, A3 or A4, an alarm signal is emitted via the relevant alarm output as the TRL output there switches to 0 (*low active*). Ex works, the alarm threshold for A1 is 30 ppm CO, A2 is 40 ppm CO, A3 is 50 ppm CO and A4 is 60 ppm CO. Customer-specific modifications to the alarm thresholds are possible.

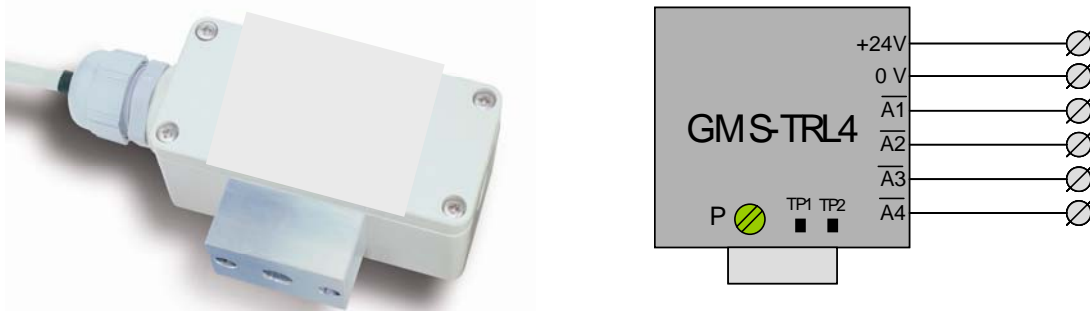

Fig. 1: GMS-TRL4 gas indicator system. P, potentiometer; TP1 and TP2, test pins; A1, A2, A3, A4, alarm outputs, TRL, *low active*. **Part no: 2112BGMS-TRL**

The outputs are short-circuit-proof.

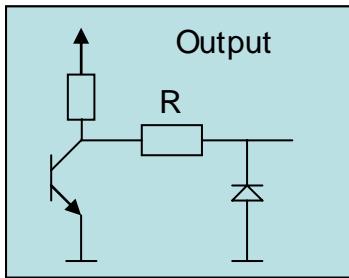

Fig. 2: Short-circuit-proof alarm outputs A1, A2, A3 and A4.

The device is calibrated using a voltmeter and test gas via the potentiometer P and two test pins TP1 and TP2. It is also possible to read the current measured values there at any time. In this case, 0.4 V corresponds to 0 ppm CO and 2 V corresponds to 300 ppm CO.

2.2 GMS-RZ

It is possible to connect 2 alarm outputs of up to 20 GMS-TRL4 gas indicator systems to the GMS-RZ relay centre. The output signals from the GMS-RZ can be picked up via potential-free relay contacts (load 250V AC 1A). Three LEDs indicate the function status.

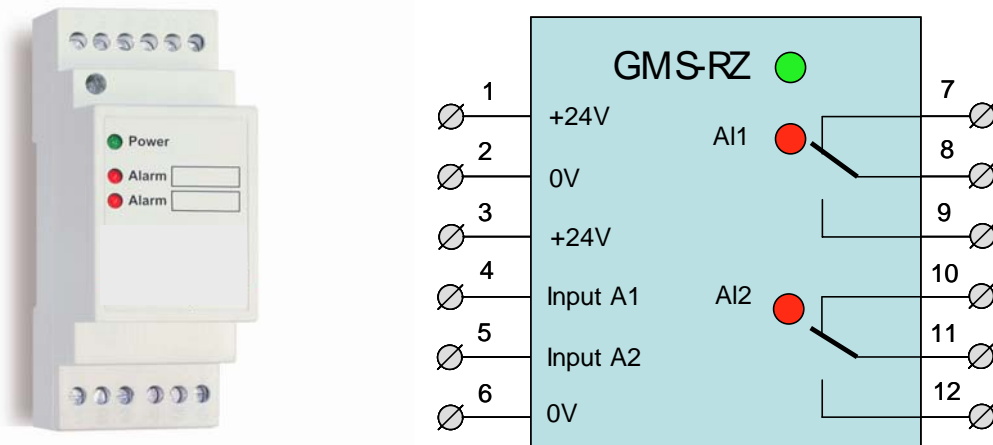

Fig. 3: GMS-RZ gas indicator system. Illustrated currentless. **Part no: 2112BGMS-RZ**

2.3 GMS-TRL4 + GMS-RZ

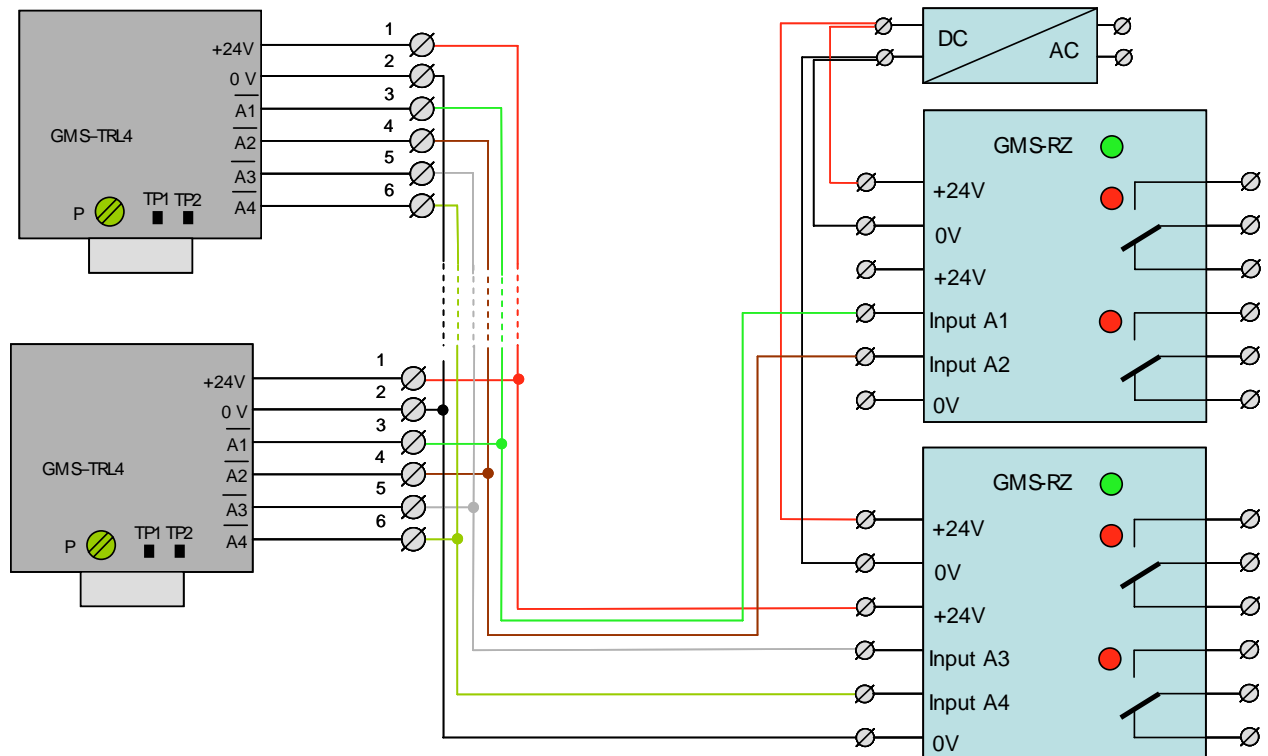

Fig. 4: GMS-TRL4 + GMS-RZ gas indicator system. Max. 20 GMS-TRLs may be connected to 2 GMS-RZs in total. Illustrated currentless.

Grouping: 1 group = 1 GMS-RZ for alarms A1 and A2 + 1 GMS-RZ for alarms A3 and A4 + all GMS-RTL4s connected to it

3. Technical data

GMS-TRL4		
Power supply		Screw terminals
	Terminal voltage	18 to 28 V DC
	Current	$I_{typ} = 20 \text{ mA}$ at approx. 10 ppm CO $I_{max} = 50 \text{ mA}$
Connections	Terminal 1 (in)	$U_{typ} = 24 \text{ V DC} \pm 5\%$
	Terminal 2 (in)	0 V
	Terminal 3 (out)	Alarm 1, <i>low active</i>
	Terminal 4 (out)	Alarm 2, <i>low active</i>
	Terminal 5 (out)	Alarm 3, <i>low active</i>
	Terminal 6 (out)	Alarm 4, <i>low active</i>

Ambient temperature	-10° C to +40° C	
Air pressure	900 hPa to 1100 hPa	
Permissible humidity	15-95% rel. humidity	
Output	TRL	Transistor Resistor Logic
	Alarm 1	30 ppm CO
	Alarm 2	40 ppm CO
	Alarm 3	50 ppm CO
	Alarm 4	60 ppm CO
Protection class of housing	IP 65	Grey plastic housing
Protection class of sensor head	IP 40	Aluminium
Weight of housing	Approx. 150 g	
Size of housing	Approx. W95 x H60 x D44 mm	
Connecting cable	6x1.5 ² Cu	Shielded cable as required; min. 18 V at supply terminal
GMS-TRL4 sensor		
Gas access	By diffusion	
Gas Measured	Carbon monoxide (CO)	
Measuring range	0 to 300 ppm	
Accuracy	Deviation < 2% from FS	FS = Full Scale
Reproducibility	Deviation < 0.5% from FS	
Reaction time T ₉₀	< 130 s	
Response sensitivity	< 3 ppm	
Error limit of measured value	< 2% from FS	
Linearity	< 2% from FS	
Zero drift	< 4 ppm	
Pressure sensitivity	< 1%	Within the range of normal air pressure fluctuations.
Cross sensitivity	< 0.5% from FS at	7 ppm SO ₂ 1 ppm NO 0.5 ppm NO ₂ 1000 ppm CO ₂ 100 ppm toluene, xylene
GMS-TRL4 controls		
Potentiometer P	Setting of measured value	
Test pins TP1 and TP2	Reading of measured value	

GMS-RZ		
Power supply		Screw terminals
	Voltage	24 V DC \pm 5%
Nominal power	Without measuring systems	Approx. 3 W
Ambient temperature	-10° C to +40° C	
Air pressure	900 hPa to 1100 hPa	
Permissible humidity	15-95% rel. humidity	
Housing	Plastic	Grey, rail
Protection class of housing	IP 20	
Weight of housing	Approx. 100 g	
Size of housing	Approx. W35 x H91 x D72 mm	
GMS-RZ connections		
External power supply	Terminal K1 (in)	24 V DC \pm 5%
	Terminal K2 (in)	0 V
GMS-TRL4	Terminal K3 (out)	24 V DC \pm 5%
	Terminal K4 (in)	Alarm A1 or A3
	Terminal K5 (in)	Alarm A2 or A4
	Terminal K6 (out)	0 V
Relay alarm AI1	Terminal 7	NC contact (normally closed)
	Terminal 8	Two-way switch
	Terminal 9	NO contact (normally open)
	Idle state	Alarm AI1
Relay alarm AI2	Terminal 10	NC contact
	Terminal 11	Two-way switch
	Terminal 12	NO contact
	Idle state	Alarm AI2
GMS-RZ optical display		
Green LED	Operation	
Red LEDs AI1, AI2	Alarm1 and Alarm2	

4. Calibrating the GMS-TRL4 gas indicator system

Manual calibration is carried out by means of the potentiometer P and two test pins TP1 and TP2. This requires a voltmeter and test gas.

5. Other

There are currently no known, nor any anticipated, sensor-specific catalyst poisons that could damage the electrochemical sensor beyond repair. The user should determine the precise suitability of any GMS-TRL4 + GMS-RZ gas indicator system by means of suitable tests under the specified conditions.

Subject to technical modifications (03/10).

The data contained in this document is believed to be accurate and reliable. The data given is for guidance only. Euro-Gas Management Services Ltd accepts no liability for any consequential losses, injury or damage resulting from the use of this datasheet or the information contained in it. Customers should test the sensors under their own conditions to ensure that the sensors are suitable for their own requirements and in accordance with the plans and circumstances of the specific project and any standards/regulations pertaining to the country in which the sensors will be utilised. This datasheet is not intended to form the basis of a contract and in the interest of product improvement, Euro-Gas reserves the right to alter design features and specifications without notice.