

ECO-SURE (2E) CO SENSOR + 4-20mA p.c.b.

Approved by TÜV according to VDI 2053 for OEM applications with CO monitoring systems for underground car parks



Figure 1

ECO-Sure CO sensor
with 4-20mA transmitter

Part no. 2112B1005

FEATURES & BENEFITS

- TÜV approval according to VDI 2053 systems.
- Signal 4 – 20 mA standard interface.
- Pre-calibrated on 0 – 300 ppm CO in air allowing direct integration with system.
- Optional range of 0-500 ppm.
- Two wire cabling reduces installation costs.
- Signal testable at pins on transmitter allowing one man testing and calibration.
- Automatic zero adjustment meaning reduced maintenance effort.
- Accessories: fixing ring, sinter metal disc and sensor holder allow easy assembly into wall mounting boxes.
- Test gas cap suitable for applying test gas.



ECO-SURE (2E) CO SENSOR + 4-20mA p.c.b.

SPECIFICATION

Detection principle:	Electrochemical
Operation:	continuous
Gas entry:	by diffusion
Measuring range:	Standard: 0 – 300 ppm CO in air Optional: 0 – 500 ppm CO
Reproducibility:	< 3ppm
Response time t90:	< 60 sec
Cross sensitivity:	< 2% on 300 ppm CO according VDI 2053
Linearity:	< 2% on 300 ppm CO according VDI 2053
Temperature range:	-10°C to +40°C
Humidity range:	15 - 95% relative humidity
Power supply:	20 – 28 V d.c.
Signal:	4 – 20 mA, max. load 300W
Zero adjustment:	automatic
Sensitivity adjustment:	via potentiometer
R.F.I. :	according EN 50 081-1 resp. EN 50 082-2 B
Storage temperature:	0 – 20 °C
Mechanical design:	CO Sensor plugged onto p.c.b. terminals on p.c.p, vertically or horizontally pluggable
Dimensions:	21 mm \varnothing , 30 nun high incl. terminals
Weight complete:	approx. 10g
Sensor housing material:	Noryl 110

Accessories:

- Installation kit (installation ring; sinter metal disc; sensor holder; O-Ring), part no: 2112B1022
- Test gas cap, part no: 2112B1010
- Gas Measuring System: Sensor, transmitter and installation kit provided as a complete unit in aluminium housing, part no: 2112B1013.



ECO-SURE (2E) CO SENSOR + 4-20mA p.c.b.

Approved by TÜV according to VDI 2053 for OEM applications with
CO monitoring systems for underground car parks



Figure 1. ECO-Sure CO sensor + 4-20mA transmitter
Standard measuring range: 0-300ppm. Optional measuring
range: 0-500ppm. Part no. 2112B1005

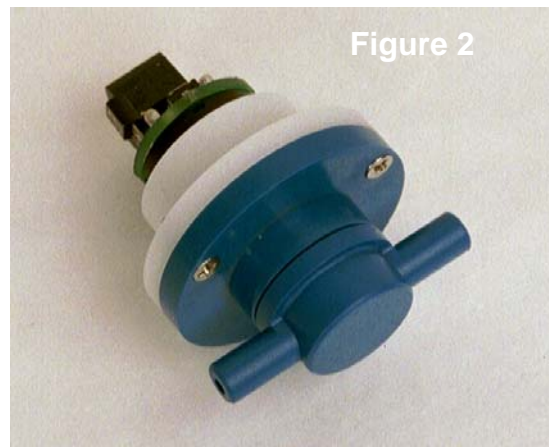

**Figure 2. ECO-Sure CO sensor plus 4-20mA transmitter with
sensor holder, screwed to blue installation ring and plugged in
to test gas cap.** Standard measuring range: 0-300ppm. Optional
measuring range: 0-500ppm. Part nos. 2112B1005, 2112B1010
This unit is ready for installation into plastic or aluminium housing.



ECO-SURE (2E) CO SENSOR + 4-20mA p.c.b.



Figure 3

Figure 3. Components from left to right: test gas cap; installation ring; sinter metal disc; sensor holder; ECO-Sure CO sensor with O-Ring and 4-20mA transmitter; pluggable terminal block.

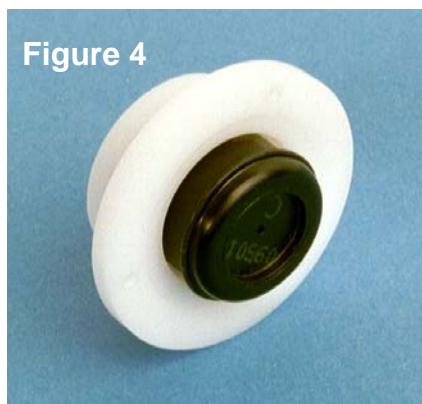

Figure 4

Figure 4. Sensor holder with half-fitted ECO-Sure sensor



Figure 5

Figure 5. Test gas cap



ECO-SURE (2E) CO SENSOR + 4-20mA p.c.b.

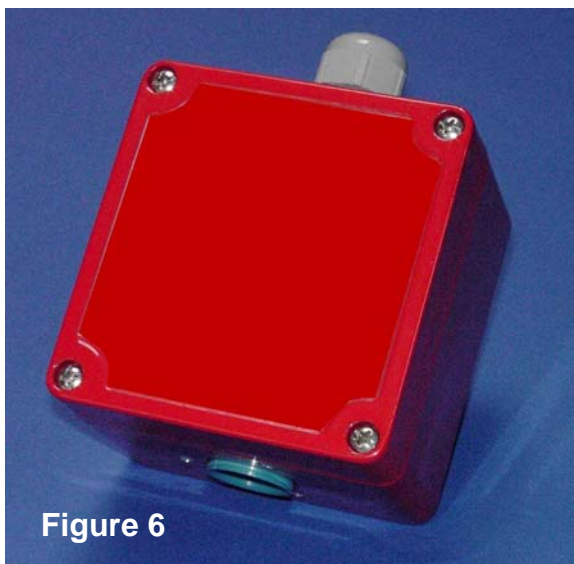

Figure 6

Figure 6. Gas Measuring System: ECO-Sure CO sensor with 4-20mA transmitter and installation kit, provided as a complete unit, fitted into aluminium housing (IP65). Part no. 2112B1013. Standard measuring range: 0-300ppm. Optional measuring range: 0-500ppm.

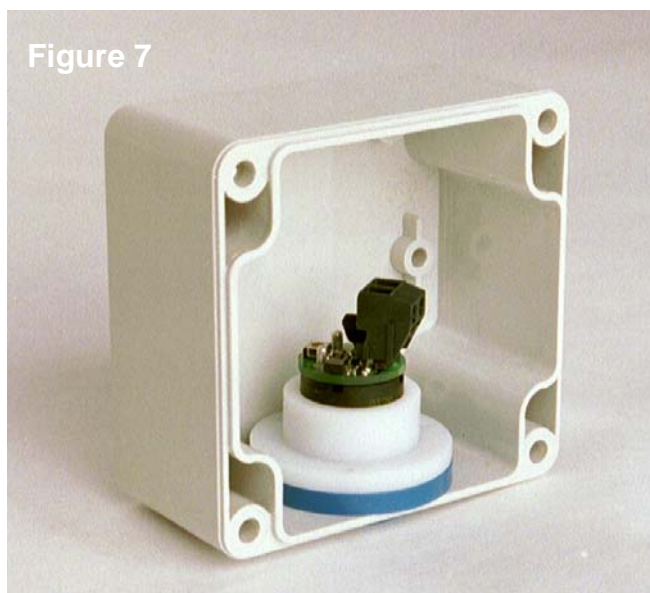

Figure 7

Figure 7. ECO-Sure CO sensor and 4-20mA transmitter with installation kit and, as an example, built into Bopla wall mounting housing (please note: Bopla plastic housing is shown as an example only and is not available from Euro-Gas).



ECO-SURE (2E) CO SENSOR + 4-20mA p.c.b.

Questions and answers

? Which components are TÜV approved according to VDI 2053 ?

! The ECO-Sure CO sensor in conjunction with the 4-20mA transmitter !

? Does an existing TÜV certificate on a complete CO monitoring system become invalid if a manufacturer undertakes a sensor change in favour of ECO-Sure + 4-20 mA transmitter ?

! No, the TÜV that has issued the original certificate will rewrite the original certificate !

? How does the automatic zeroing circuit work ?

! This is a company secret !

? Which cross-sensitivities are to be expected with the ECO-Sure CO sensor ?

! The cross-sensitivity on the ECO-Sure CO sensor has been tested by TÜV according to the requirements of VDI 2053 and shows a cross-sensitivity to other gases in an underground car park that is much lower than tolerated !

? What does "ECO-Sure" mean ?

! 1) **ECO** means cost-effective

2) **Sure** is its relationship to the "SureCell" technology of the manufacturer.

It has the highest possible performance at extreme high and low atmospheric humidities, and a reproducible temperature profile and high quality sealings to prevent leaks !

? Are the terminals marked with + resp. - ?

! There is free choice on the polarity !



ECO-SURE (2E) CO SENSOR + 4-20mA p.c.b.

Questions and answers

? Why is there a sinter metal disc with the accessories ?

! The sinter metal disc protects the CO sensor from dust and splash water and restrains test gas turbulence within the test gas cap. Furthermore, the sinter metal disc protects the CO sensor from vandalism !

? Is the usage of the sinter metal disc mandatory ?

! No, instead of the sinter metal disc, any other protection against dust and water can be used, for example a Goretex disc !

Tips + Tricks

When using the test gas cap for regular testing and calibration, a test gas flow of 0.3l/min or 0.5 l/min is recommended.

For gluing the CO sensor into the installation ring, a glue which is free from hydrocarbons and solvents has to be used.

When the ECO-Sure CO sensor is plugged into the 4-20mA transmitter, the CO sensor is perfectly stabilised. However, if the CO sensor is separated from the 4-20mA transmitter for any reason, the CO sensor should be left without power for a time period of 2 – 3 hours for stabilisation purposes before replugging the CO sensor back into the 4-20mA transmitter.



ECO-SURE (2E) CO SENSOR + 4-20mA p.c.b.

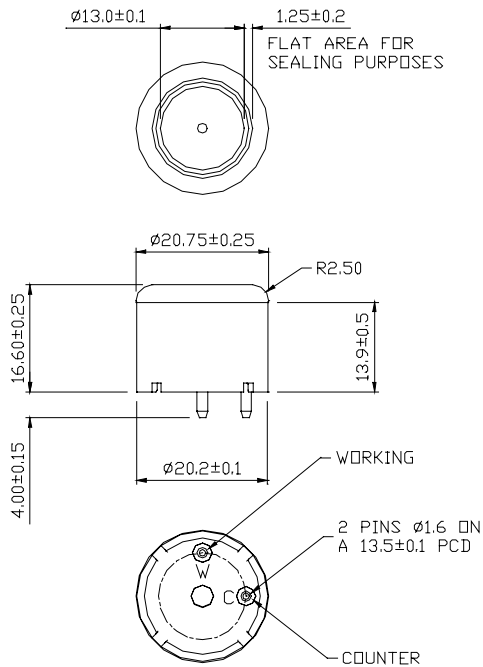

ECO-Sure CO sensor
top surface with
gas entry hole

ECO-Sure CO sensor
side view

ECO-Sure CO sensor
back view with
connecting plugs

Figure 8. ECO-Sure CO sensor dimensions

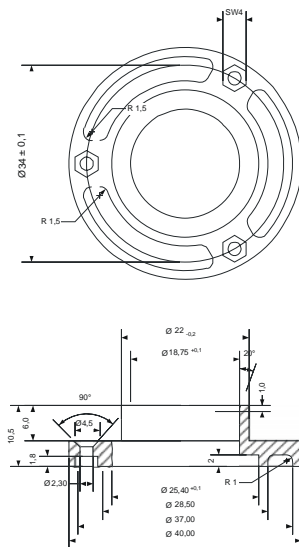

Werkstoff :
Novodur PH-AT571 CF (blau)

Figure 9. Installation ring



ECO-SURE (2E) CO SENSOR + 4-20mA p.c.b.

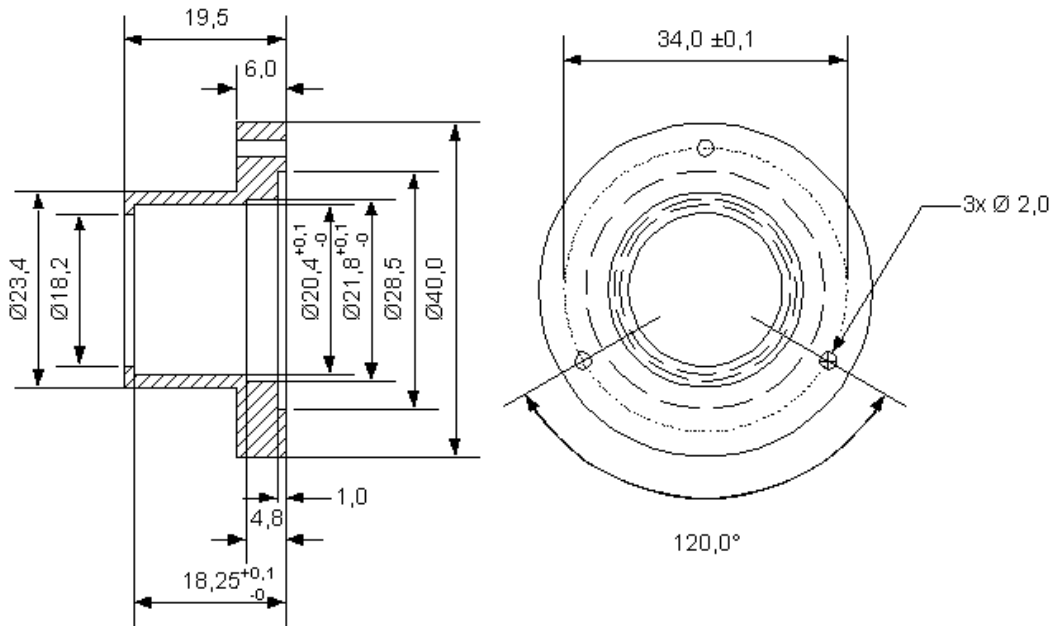

Figure 10. Sensor holder

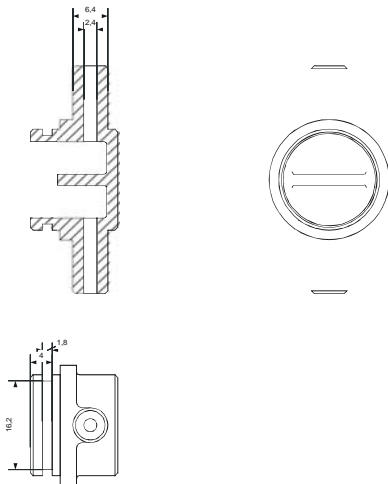

Figure 11. Test gas cap

The data contained in this document is believed to be accurate and reliable. The data given is for guidance only. Euro-Gas Management Services Ltd accepts no liability for any consequential losses, injury or damage resulting from the use of this datasheet or the information contained in it. Customers should test the sensors under their own conditions to ensure that the sensors are suitable for their own requirements and in accordance with the plans and circumstances of the specific project and any standards/regulations pertaining to the country in which the sensors will be utilised. This datasheet is not intended to form the basis of a contract and in the interest of product improvement, Euro-Gas reserves the right to alter design features and specifications without notice.

08/10



ECO-SURE (2e) CO SENSOR + 4-20 mA p.c.b. Operating Instructions

Potentiometer

for calibration adjustment

Please note: No zero adjustment required as automatically compensated

Test Gas

For calibration, flow 300ppm or required concentration of CO through a test flow cap. Test Gas Cap, installation kit and Calibration Gases also available from Euro-Gas. Please ask for details

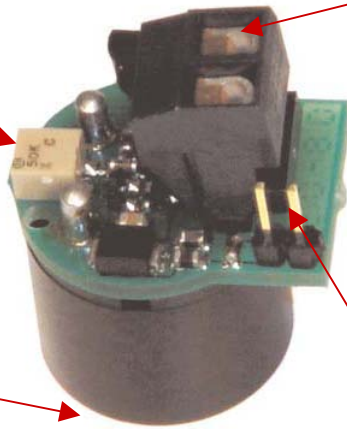

Two wire screw terminal

for 24V d.c. power supply (+/-10%); +4-20mA signal output

Please note: No polarity (+/-) requirements

Test pins for one man calibration; 0.4 – 2.0 volts signal output



Test gas cap

Part no. 2112B1010

Two wire screw terminal: The transmitter has a two wire screw terminal to connect a 24V d.c. power supply. There is no polarity requirement across the two screw terminals (i.e. there is no +/- logic).

On the same two wires, you will receive the 4-20 mA signal output. The transmitter is precalibrated on 0-300ppm CO. When there is zero CO concentration, you will receive a 4mA signal. With a 300ppm, you will receive a 20mA signal.

Potentiometer: This is used for adjusting the signal to the correct value if you apply a test gas concentration to the transmitter and it gives an incorrect signal.

Test pins: The two test pins allow for one man calibration. Please kindly note that the signal here is not 4-20 mA but **0.4 – 2.0 Volts**.

Carbon Monoxide concentration	0ppm	100ppm	200ppm	300ppm
Signal at wires	4 mA	9.33 mA	14.7 mA	20 mA
Signal at test pins	0.4 V	0.93 V	1.47 V	2.0 V

